

Patient Sling Lifting Scale

FEATURES

- **Capacity 200 Kg x 100g.**
- **Compact and easy to mount add-on unit to common patient lifters.**
- **2000 d single range OR 1600 d dual range application (acc. to OIML R 76).**
- **High safe load limit.**
- **Very low current consumption.**
- **Provides all basic scale functions.**
- **G-factor correction after verification w/o affecting sealing.**
- **Protection class IP 54 according to EN 60529.**



DIMENSIONS

(in mm; 1 mm= 0.03937 inches)

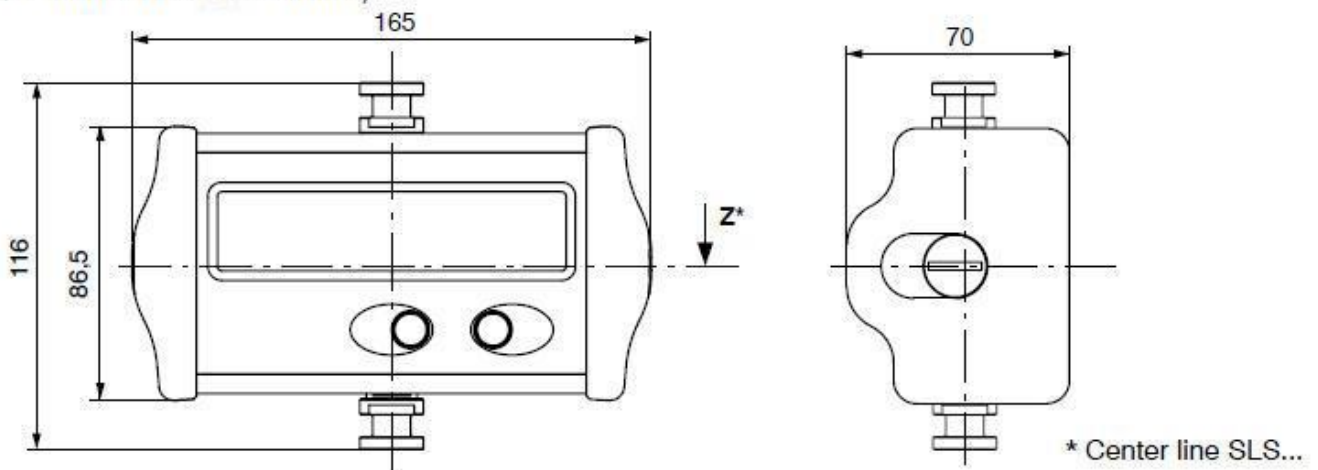

Components at disposal:

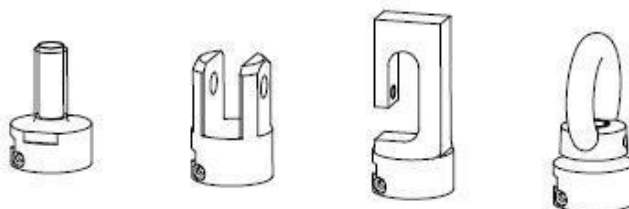

SPECIFICATIONS

Type		SLS	SLSC2	SLSC2-MR
Accuracy class according to OIML R76		-	C2	C2/C1,6
Maximum number of scale intervals $d1=e1$ $d2=e2$		10000	2000	2000 1600
Maximum capacity (E _{max})	Max 1 Max 2	kg	200	200 320
Minimum verification interval	e1 e2	g	20	100 200
Safe load limit (EL)		kg	500	
Breaking load (Ed)		kg	1000	
Display			5 digits	
Battery			4 x AA cells	
Battery Life (AA Cell with 1600mAh)		h	270	
Battery Voltage		V	3.6 ... 6V	
Current Consumption - Active Mode		mA	<6	
Quiescent current, stand-by mode		mA	<0.001	
Nominal Temperature range		°C	-10 ... +40	
Operating Temperature range		°C	-20 ... +60	
Storage Temperature range		°C	-40 ... +85	
Dimensions		mm	164 x 87 x 70	
Weight		kg	approx. 0.7	
Protection class acc. To DINN 40050(IEC529)			IP54	

OPTIONAL COMPONENTS

