

EB Series

Compact Bench Scales



The OHAUS EB Series Compact Bench Scale – Utility, Portability, OHAUS Quality and Value.

Weigh, count, checkweigh, checkcount, percent weigh—the OHAUS EB Series Scale is a multi-function weighing scale designed as a cost-effective, high-performance equipment for a multitude of light to medium industrial applications. With fast and accurate displayed results, multiple functionality and internal battery operation, the OHAUS EB Series offers versatility, portability and dependability in one affordable package.

Standard Features Include:

- Maximum displayed resolution of 1:30,000
- Stainless steel weighing pan
- Four weighing units: kg, g, lb and oz
- Application modes: Checkweighing, Counting and Percent Weighing
- User-programmable weight and parts HI/LO checking mode with audible buzzer
- 80-hour internal rechargeable battery with power-saving auto-shut off feature
- Included in-use cover
- Industry leading quality and support

EB Series Compact Bench Scale

Specifications	EB3	EB6	EB15	EB30
Capacity x Readability	6.6 lb x 0.0002 lb 105 oz x 0.005 oz 3 kg x 0.0001 kg 3,000 g x 0.1 g	13 lb x 0.0005 lb 208 oz x 0.01 oz 6 kg x 0.0002 kg 6,000 g x 0.2 g	33 lb x 0.001 lb 528 oz x 0.02 oz 15 kg x 0.0005 kg 15,000 g x 0.5 g	66 lb x 0.002 lb 1056 oz x 0.05 oz 30 kg x 0.001 kg 30,000 g x 1 g
Maximum Displayed Resolution	1:30,000	1:30,000	1:30,000	1:30,000
Construction	Stainless steel pan, plastic housing			
Weighing Units	lb, oz, kg, g			
Application Modes	Weighing, Counting, Checkweighing, Percent Weighing, Accumulation			
Repeatability (std. deviation)	1d			
Linearity	± 1d			
Display	1-window backlit LCD display, 1-inch / 25.4 mm high, 6-digit, 7-segment			
Display Indicators	Stability, Center of Zero, Gross, Tare, Battery Status, Hi-Ok-Lo, Units			
Hi-Lo Check Indicators	Display with alert beeper			
Keyboard	7 raised tactile membrane switches: M+, Units, Zero, Tare, Check, Count, %			
Zero Range	4% of full scale capacity			
Tare Range	Full capacity by subtraction (except EB15, up to 10kg only)			
Stabilization Time	≤ 2 seconds			
Operating Temperature	32°F to 104°F / 0° to 40°C			
Humidity Range	≤ 90% relative humidity, non-condensing			
Power	AC Adapter 12V DC / 800mA Internal rechargeable sealed lead acid battery			
Battery Life	80 hours continuous use with 12 hour recharge time			
Calibration	External with kg/g mass, factory calibration recovery			
Shipping Protection	Shipping screw to avoid damage to sensitive components			
Safe Overload Capacity	120% of capacity			
Pan Size (W x L)	11.6 x 8.9in / 294 x 226mm			
Scale Dimensions (W x L x H)	12.8 x 13 x 4.5in / 325 x 330.5 x 114mm			
Shipping Dimensions	17.3 x 14.2 x 6.3in / 440 x 360 x 160mm			
Net Weight	9.3lb / 4.2kg			
Shipping Weight	11.7lb / 5.3kg			
Other Features	Auto-zero tracking, filtering level			

Approvals

- **Electrical/Emissions:** Meets requirements of approval agencies: UL (adapter), FCC, CE Safety EN61558, EMC EN61326

Outline Dimensional Drawings

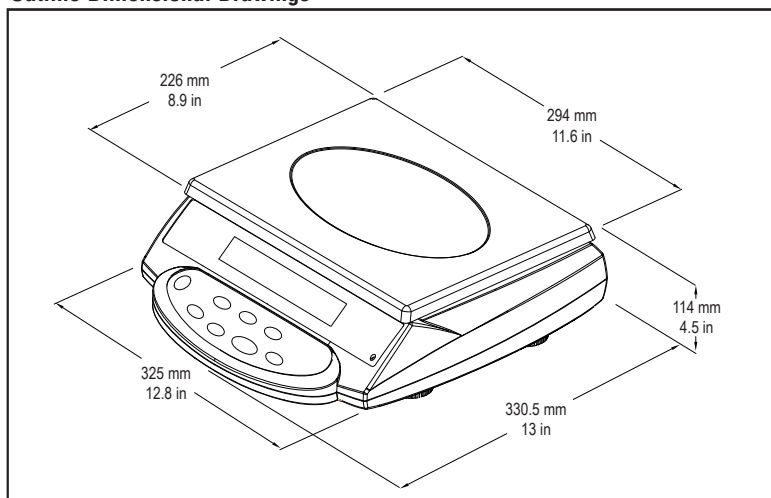

Hills Scales Pty Ltd
Tel.: (02)8850 4666

Web: www.hillscales.com.au
Email : sales@hillscales.com.au