

C1000 Series Mailroom Scale



FEATURES

- ABS plastic housing
- Low battery warning
- Rubber non-slip feet
- Built in carry handles
- AC power or 3 "C" batteries
- "Stand on me" – extreme overload protection

DIMENSIONS

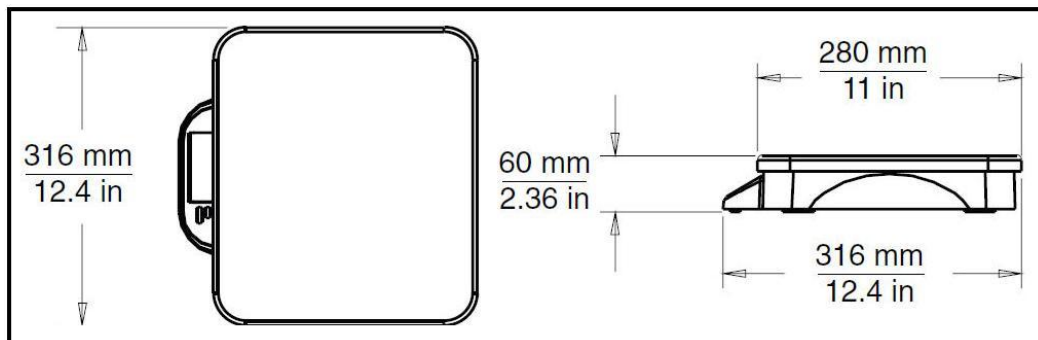

SPECIFICATIONS

Model	C11P9	C11P20	C11P75
Capacity (lb)	20	44	165
Readability (lb)	0.01	0.02	0.1
Capacity (kg)	9	20	75
Readability (kg)	0.005	0.01	0.05
Weighing Units/Modes	lb,kg		
Functions	Averaging mode, Stability indicator, Low battery, Auto Zero Tracking Auto Shutoff		
Keyboard	Two mechanical switches		
Calibration	Digital External Span calibration		
Display	LCD Total Viewing area: 26 mm H x 70 mm W		
Display Indicators	7 segment 4 digit		
Tare Range	Full capacity by subtraction		
Stabilization Time	<=2 seconds		
Operating Temp/humidity	5° C to 40° C at 10% to 80% relative humidity, non-condensing		
Construction	ABS plastic housing and pan, Stainless Steel pan option		
Power	AC powered (included) or 3 1 1/2 volts C Batteries (not included)		
Battery Life	300 hours with alkaline cells, auto off after 4 minutes of inactivity		
Dimensions mm (LxWxH)	266 x 304 x 60		
Pan size mm (LxW)	280 x 316		
Net Weight	1.5 kg (not including AC adapter)		