

## TN Crane Scales

### General Specifications

- Display 30mm digits LCD display with LED backlight (TN-LCD)
- Capacities 600kg~12t
- Keyboard 5 keys(Mechanical switch)
- Housing Die-casting aluminum
- Max. Divisions 3x3,000d
- ADC Sigma delta
- ADC update  $\leq 1/10$  second
- Operate Temp  $-10^{\circ}\text{C} \sim +40^{\circ}\text{C}$
- Power AC adapter(12V/2500mA),  
Rechargeable Li battery 7.4V 5200mA



- Application: 1. Tare 2. Hold 3. Accumulation 4. Weighing units conversion
- Battery provide up to 60 hours of continuous use(without backlight)
- Optional remote controller
- Optional Bluetooth application
- Overload records management

# TN Crane Scales

Model Name	Capacity	Readability	Division	Approx. weight
TN-600kg	150kg/300kg/600kg	0.05kg/0.1kg/0.2kg	3x3,000d	11kg
TN-1500kg	300kg/600kg/1500kg	0.1kg/0.2kg/0.5kg	3x3,000d	11kg
TN-3000kg	600kg/1500kg/3000kg	0.2kg/0.5kg/1kg	3x3,000d	11kg
TN-6000kg	1500kg/3000kg/6000kg	0.5kg/1kg/2kg	3x3,000d	20kg
TN-12000kg	3000kg/6000kg/12000kg	1kg/2kg/5kg	3x3,000d	25kg

## Options

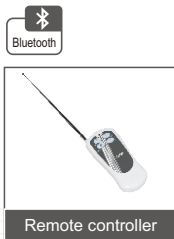

## Dimensions(mm)

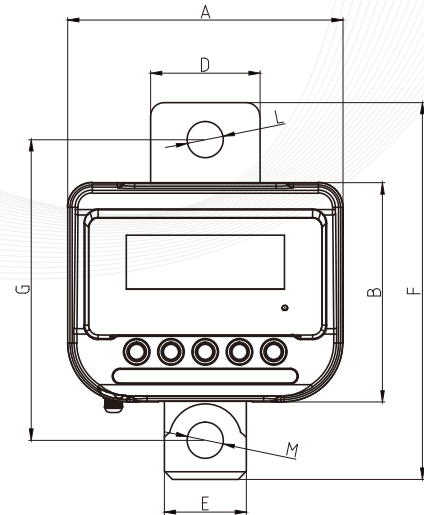
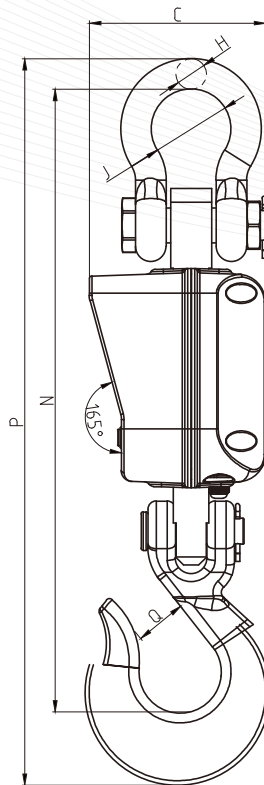
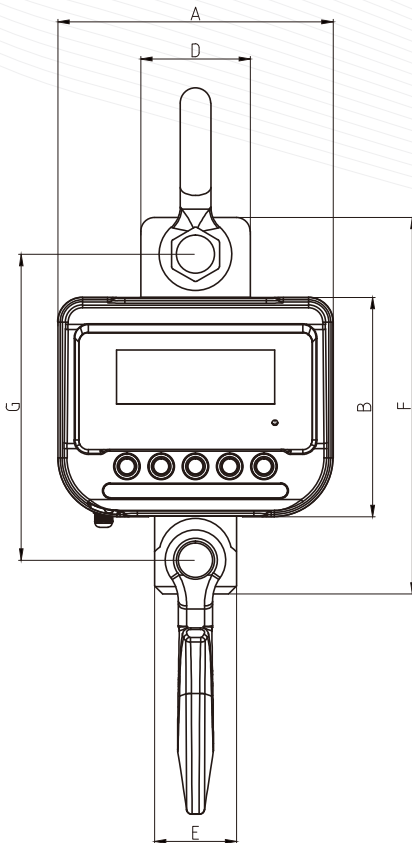

DIM (mm) \ CAP	600kg	1.5T	3T	6T	12T
A	201	201	201	201	201
B	160	160	160	160	160
C	128.5	128.5	128.5	128.5	128.5
D	80	80	80	95	95
E	60	60	60	80	80
F	270	270	275	320	330
G	219	219	219.5	248	247.5
H	φ 19	φ 19	φ 22	φ 25.4	φ 31.8
J	φ 50.8	φ 50.8	φ 58	φ 68.3	φ 82.5
L	φ 23	φ 23	φ 26.5	φ 30	φ 36
M	φ 23	φ 23	φ 26.5	φ 30	φ 36
N	415	415	456	528	557
P	477	477	532	624	660
Q	42.9	42.9	50.8	63.5	63.5