



Legal for trade food scale that enhances safety, efficiency, and productivity even in harsh environments!

The OHAUS Valor 4000 water resistant food scale raises the bar and sets a new industry standard with the winning combination of touchless operations, speed, and durability. Available in both stainless steel and plastic housing designs, Valor 4000 offers large LED front and rear displays, puncture resistant keypads, and is NSF Certified, OIML/EC Type Approved and supports HACCP Certified systems, making it the premiere scale for use in dry or washdown environments.

Standard Features Include:

- **Approvals Ensure Operation in the Most Demanding Environments** — With Legal for Trade certifications and food-safe washdown design that's NSF Certified, OIML/EC Type Approved and supports HACCP Certified systems, Valor 4000 meets the needs of the most demanding commercial applications in dry or wet environments.
- **Fast Speed, Practical Touchless Sensors, and Multiple Weighing Modes Enhance Productivity** — Touchless sensors combined with a half second stabilization time increase the productivity of weighing operations without sacrificing accuracy. Additional checkweighing and percent weighing modes increase the functionality of this efficient scale.
- **The Flow-Thru Design Protects Valor 4000 in Harsh Environments** — Safe to use in the weighing of liquids and in wet environments, Valor 4000's flow-thru design ensures the scale is protected from damage from liquids.
- **Knife Proof Keypad Prevents Damage from Sharp Objects** — Valor 4000 has a polycarbonate keypad that can endure being touched by knives or sharp instruments used daily in demanding food preparation, processing and portioning applications.

Valor[®] 4000 Compact Bench Scale

Approvals Ensure Operation in the Most Demanding Environments

The Valor 4000 provides precise measurements with OIML / EC Type Approval to meet or exceed the Class III accuracy requirements in accordance with EC Directives and EN45501. Easy to clean and sanitary design make Valor 4000 as NSF Listed/Certificated and support HACCP - Certified systems.



Fast Speed, Practical Touchless Sensors, and Multiple Weighing Modes Enhance Productivity

Don't sacrifice speed or precision for the other – with Valor 4000, you will have both! Valor 4000 not only has a maximum external resolution of 1:6,000/1:7,500, but it displays results in less than half a second. Coupled with a touchless infrared sensor next to the back display which allows a second operator to tare the scale with simply a swipe of the hand without having to wait for the other operator to press the Tare button, Valor 4000 was created to support speedy use. In addition to standard weighing, Valor 4000 offers checkweighing, accumulation and percent weighing modes.



The Flow-Thru Design Protects Valor 4000 in Harsh Environments

The flow-thru IPX8, water-resistant design allows for weighing of liquid components and can be used in harsh environments by channeling fluids that may enter the housing to strategically located drain holes, ensuring the scale remains clean and operational. The internal components and connections are silicone sealed to protect the scale from fluids and from condensation that may form inside the scale from constant temperature changes in a typical processing environment. The scale can be easily washed off at the end of each shift to keep it in sanitary condition and avoid the growth of bacteria from food contaminants.



Knife Proof Keypad Prevents Damage from Sharp Objects

The Valor 4000 has a highly durable 0.5 mm thick polycarbonate keypad which is impact and puncture resistant. Valor 4000's smooth glossy surfaces easily repel stains, moisture, corrosive fluids and food contaminants, and stainless steel models offer an extra layer of protection.

Application Modes

- **Weighing** — Determine the weight of items in one or more weighing units -- g, kg -- use the 0.2g to 5g readability for weighing additives, spices and yeast.
- **Percent Weighing** — The Valor 4000 includes % weighing for recipe formulation and baker's percentages. Just weigh the flour on the Valor's platform, capture the reference weight and all other ingredients can be weighed as a % of the flour weight, making small batches of dough quick and easy to work up! Practical use in formulation, ingredients weighing and baker's percentage.
- **Check Weighing** — Use the bright red/yellow/green LED's to easily fill containers and packages by weight -- great for sorting, grading and portioning.
- **Accumulation** — Keep a running total of all items by weight for recording long production run results.

Power and Portability

The 100-240 VAC universal power adapter can be operated from virtually any power source and can automatically switch to adapt to different power and voltage lines.

When plugging your machine in is not an option, the built-in, rechargeable lead acid battery will provide power for 50 continuous hours, ensuring uninterrupted operation for more than a full week!

Adapter connection cover underneath the scale is spring loaded to ensure the power receptacle is protected from the ingress of moisture, especially when the scale is washed down.

Large Dual Displays

With bright front and rear LED displays, more than one operator can utilize the scale for the same job. Even in less than optimal conditions, large, brightly lit screens ensure you can see your results with ease even from a distance.

Dual displays also allow for quick and easy weighing in retail use. The large displays on the front and back of the Valor 4000 allow it to be used in countertop retail applications where the customer needs to see the weight on the platform.

Non-Slip Leveling Feet

Large fully rubberized feet are located at extreme corners of the scale to ensure a wide stance and surface resistance that minimizes the risk of the scale sliding or falling off smooth surfaces. The rubber of the feet extends to the shaft that ensures no grooves are exposed when fully extended; a design that passes NSF standards.

Certifications

The Valor 4000 is Certified to NSF/ANSI 169 Special Purpose Food Equipment and Devices and Hygiene Requirements for the Design of Meat and Poultry Processing Equipment.

The Valor 41...M Models are designed and engineered to meet stringent OIML and NAWI Directive (Non Automatic Weighing Instruments) requirements for use in legal and prescribed applications such as in standard industries, stores or QC laboratories. The Valor 41...M Models have been designed and verified to meet or exceed the Class III accuracy requirements in accordance with EC Directives and EN45501.



Rear Display with Integrated Touchless Sensor

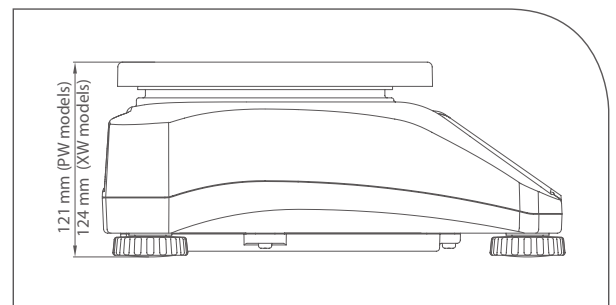
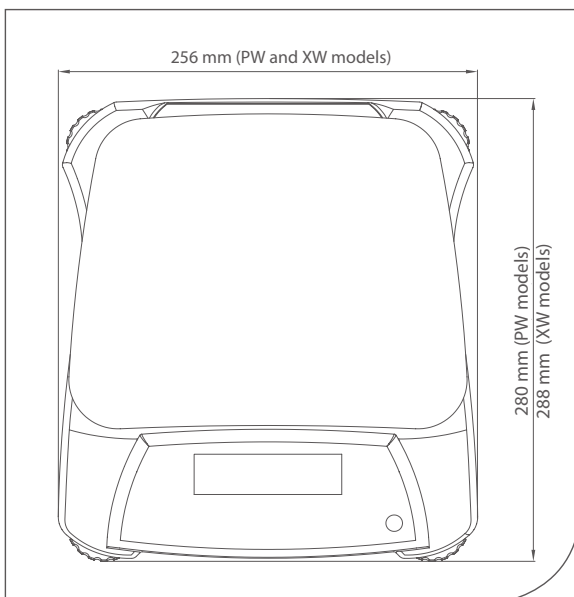

Valor® 4000 Compact Bench Scale

Model	V41PWE1501T V41XWE1501T	V41PWE3T V41XWE3T	V41PWE6T V41XWE6T	V41PWE15T V41XWE15T
Capacity x Readability	1.5 kg x 0.0002 kg 1500 g x 0.2 g	3 kg x 0.0005 kg 3000 g x 0.5 g	6 kg x 0.001 kg 6000 g x 1 g	15 kg x 0.002 kg 15000 g x 2 g
Maximum Displayed Resolution (d)	1:7,500	1:6,000	1:6,000	1:7,500
Model	V41PWE1501T-M V41XWE1501T-M	V41PWE3T-M V41XWE3T-M	V41PWE6T-M V41XWE6T-M	V41PWE15T-M V41XWE15T-M
Certified Capacity x Readability	1.5 kg x 0.0005 kg 1500 g x 0.5 g	3 kg x 0.001 kg 3000 g x 1 g	6 kg x 0.002 kg 6000 g x 2 g	15 kg x 0.005 kg 15000 g x 5 g
Certified Resolution	1:3,000	1:3,000	1:3,000	1:3,000
Weighing Units	g, kg			
Application Modes	Weighing, Percent Weighing, Checkweighing, Accumulation			
Keyboard	Four mechanical switches with polycarbonate overlay			
Calibration	Digital external span calibration			
Display	7 segment, 6 digit, 20.5 mm / 0.8 in high red LED dual display			
Display Indicators	Stability, Center of Zero, Net, Battery Status, IR sensor and Accumulation			
Checkweighing Indicators	3 LED (yellow, green, red) with configurable operation			
IR Sensor	Rear side for Tare function			
Tare Range	To capacity by subtraction			
Zero Range	4% - 20% of Capacity			
Stabilization Time	≤0.5 second			
Safe Overload Capacity	150% of capacity			
Operating Temperature Range	-10 °C to 40 °C / 14° F to 104° F, 10% to 90% relative humidity non-condensing			
Construction	V41PW: Stainless steel platform, ABS housing V41XW: Stainless steel top housing and platform, ABS bottom housing			
Power	12V DC 0.84A, AC Universal adapter (100 - 220V AC / 50 -60Hz) and built-in internal rechargeable lead acid battery included			
Battery Operation	Typically 50 hours of continuous use with 12-hour full charge			
Ingress Protection	Fully Waterproof			
Platform Size	190 x 242 mm			
Scale Dimensions (W x D x H)	V41PW: 256 x 280 x 121 mm V41XW: 256 x 288 x 124 mm			
Shipping Dimensions (W x D x H)	410 x 370 x 220mm			
Net Weight	V41PW: 3.0 kg V41XW: 3.9 kg			
Shipping Weight	V41PW: 4.0 kg V41XW: 4.9 kg			

Other Standard Features and Equipment

- Adjustable feet, level bubble with lighting, menu and mode setup navigation prompts on keys, easy transportation carrying handle, stainless steel pan and chemical-resistant overlay, new mechanical keys, a cover with spring to protect power connector of scale

Approvals

- **Metrology:** OIML R76-1:2006 (R76/2006-NL1-13.09); EN 45501:1992 (T8312); Australia National Measurement Regulations (NMI 6/4C/283) – Class III 3000e
- **Product Safety:** IEC 61010-1:2010; EN 61010-1:2010
- **Electromagnetic Compatibility:** IEC 61326-1:2005; EN61326-1:2006 – Class B emission, Industrial immunity; C-Tick
- **Food Safety:** NSF/ANSI 169-2009; NSF/ANSI /3-A 14159-1-2010
- **Other:** WEEE/RoHS

OHAUS CORPORATION
www.ohaus.com
ISO 9001:2008
 Registered Quality
 Management System

80774688_A © Copyright OHAUS Corporation

