

QHW Compact Scale

FEATURES

- 24mm digits high LCD display
- Function include check weighting, counting, percentage, accumulate and weighing units conversion
- Rechargeable battery operation
- Check weighing function (user can set hi/low limit for weighing, counting and percentage)
- Auto backlight display
- Optional RS-232C communication port



TECHNICAL DATA

MODEL	QHW	QHW plus
External resolution	1/30,000	1/60,000
Display	24mm LCD, attached backlight	
Pan size	230mmx300mm	
Keyboard	7 keys embossed membrane keyboard	
Operate temp	0°C ~ +40°C	
ADC	sigma delta	
ADC update	≤ 1/10 second	
Internal counts	600,000	
Rating	AC adapter (9V/800mA) Internal rechargeable battery (6V/4Ah)	

DIMENSIONS

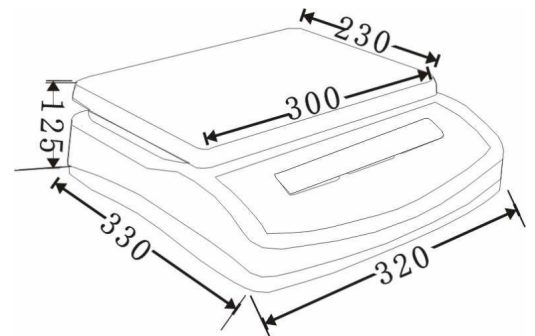

SPECIFICATIONS

MODEL	QHW-3	QHW-3 plus	QHW-6	QHW-6 plus	QHW-15	QHW-15 plus	QHW-30	QHW-30 plus
Capacity	3Kg		6Kg		15Kg		30Kg	
Readability	0.1g	0.05g	0.2g	0.1g	0.5g	0.2g	1g	0.5g
Tare Range	3Kg	1Kg	6Kg	6Kg	10Kg	10Kg	30Kg	10Kg
Pan Size	230mm x 300mm							
Gross Weight	5.1 Kg							