

Portable Axle Weighing Scale

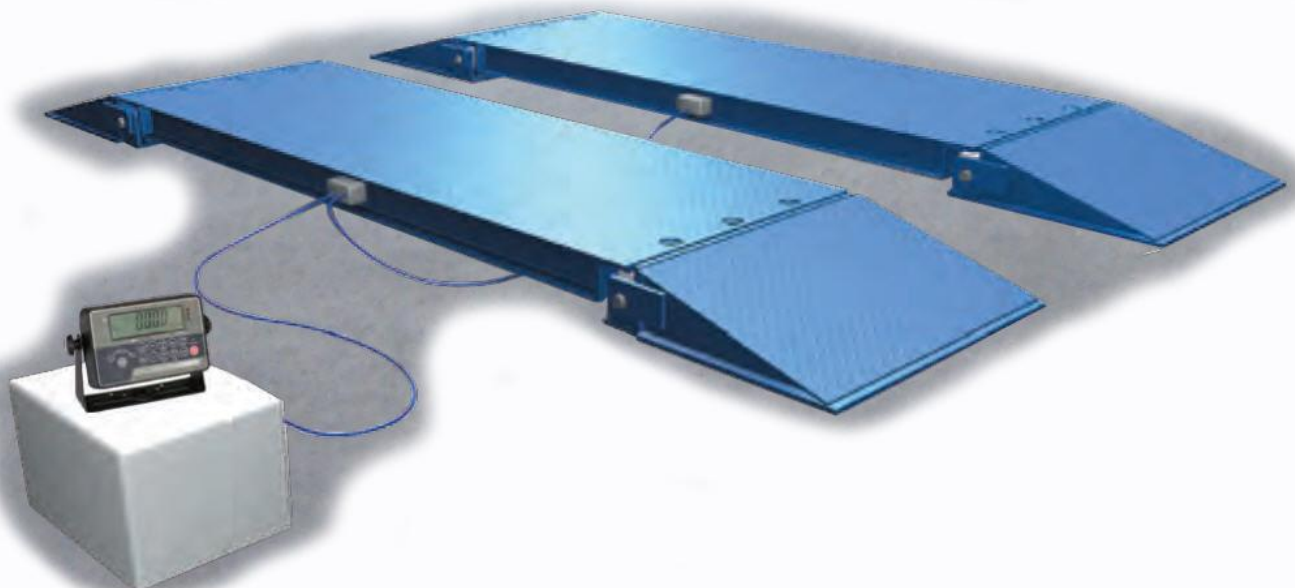

FEATURES

- ***Low Profile Design (210mm High)***
- ***Heavy Duty Steel Construction***
- ***Choose Between Galvanised or Painted Finish***
- ***Portable Design - Can Be Moved Easily***
- ***Loadcell Components Protected from Hazards***
- ***Detacheable Headwork.***
- ***Trade Versions Available***
- ***Fast User Friendly Installations***
- ***High Capacity Loadcells with 100% Overload Factor***
- ***Hermetically Sealed Loadcells***
- ***Digital Display Standard***
- ***Rechargeable Battery Operated***
- ***These Pads May Be Lifted Into Position With a Forklift and Set Down on Hard Compacted Surfaces.***



SPECIFICATIONS

- **Capacity (Per Loadcell): 25 Tonne**
- **Overload Capacity: 100%**
- **Temperature Compensation: -10 °C to +50 °C**
- **Length Per Module: 4500 mm**
- **Width Per Module: 1450 mm**
- **Weighbridge Accuracy: 10kg**
- **Weighbridge Capacity: 30 Tonne per module (up to 10 Modules)**
- **Weighbridge resolution opt: 5,10,20kg**
- **Ramps: 4 as standard (800mm long 1450 wide)**

DIMENSIONS

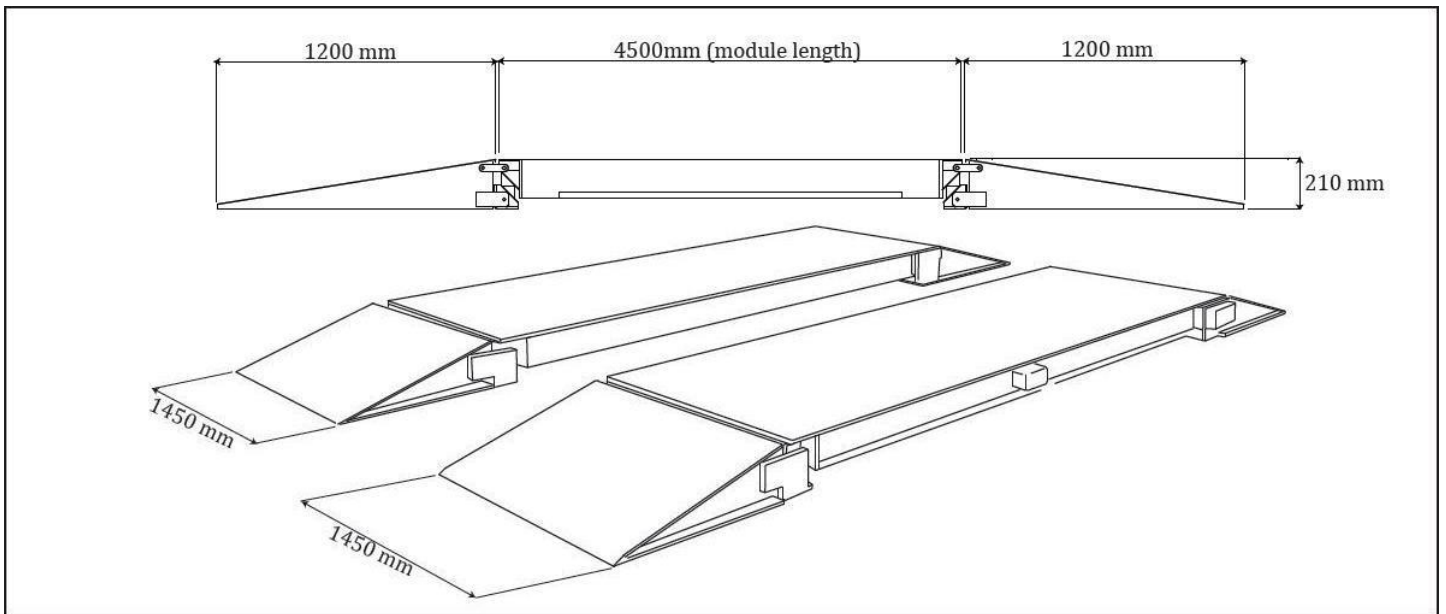

OPTIONS

- **Printers**
- **Boom Gates**
- **Traffic Lights**
- **Large Displays**
- **Prox / ibuttons**
- **Modular Add Ons**
- **Cable Extensions**
- **Software and Hardware for Computers**

