



165lb and 440lb models available with large platform



The OHAUS SD Shipping Scale – Portability, Durability, OHAUS Quality and Value

The OHAUS SD is a robust portable bench scale designed specifically with affordability, utility and everyday usage in mind. Ideal for home office, mail room, shipping and receiving, and general commercial and industrial weighing applications, the model SD features durable painted steel treaded and non-treaded platforms, a remote indicator with two tactile function keys, battery operation and flexible mounting capabilities. The OHAUS model SD is your efficient solution to a variety of weighing needs, when you need it, where you need it.

Standard Features Include:

- Now with Dynamic weighing functionality
- 3 popular capacity models: 77lb/35kg, 165lb/75kg, 440lb/200kg
- 2 platform sizes: 12.4 x 11 inches and 20.5 x 15.7 inches
- Maximum displayed resolutions from 1:1,750 to 1:2,200
- ABS plastic indicator housing with reinforced ribs
- Universal table/wall mounting brackets included
- Flexible coiled cable, extendable to 108 inches
- Painted steel platforms with raised embossed treads (SD35, SD75 and SD200 models)
- Rubber feet (adjustable on SD75L and SD200L models)
- LCD with fast weight display in lb or kg
- Raised tactile keys
- AC adapter (included) or 360 hour battery operation with Auto-Shut Off feature
- Calibration in lb or kg
- Carry handle on packaging (non-L models) for ease of portability

SD Shipping Scale

Model	SD35	SD75	SD200	SD75L	SD200L
Capacity x Readability	77lb x 0.05lb 35kg x 0.02kg	165lb x 0.1lb 75kg x 0.05kg	440lb x 0.2lb 200kg x 0.1kg	165lb x 0.1lb 75kg x 0.05kg	440lb x 0.2lb 200kg x 0.1kg
Maximum Displayed Resolution	1:1750	1:1650	1:2200	1:1650	1:2200
Calibration Weights (fixed)*	50lb / 25kg	100lb / 50kg	200lb / 100kg	100lb / 50kg	200lb / 100kg
Base Size	12.4"L x 11"W x 1.77"H / 316L x 280W x 45H mm			20.5"L x 15.7"W x 3"H / 520L x 400W x 75H mm	
Construction	ABS plastic indicator housing and mounting brackets Painted steel base with raised, embossed tread pan (non-L models) Rubber feet (adjustable on L models)				
Weighing Units	kg, lb				
Application Modes	Weigh, Dynamic weighing				
Display	4-digit, 7-segment LCD, 0.8" / 20mm high,				
Keyboard	2 function raised tactile mechanical switches: [ON/OFF Zero] / [UNITS Cal]				
Stabilization Time	≤ 3 seconds				
Cable Length	Extendable 72" to 108" / 1.8m to 2.7m (full extension)				
Operating Temperature	41° to 104°F / 5° to 40°C / 10%-80% relative humidity, non-condensing				
Power	9V DC/100mA AC Adapter (included), or 3 "C" alkaline batteries (not included)				
Battery Operating Time	360 hours				
Auto-Shut Off	4 minutes with no activity (battery operation only)				
Safe Overload Capacity	150% of capacity				
Indicator Size	8.27"L x 3.58"W x 1.54"H / 210L x 91W x 39H mm				
Shipping Dimensions	15"L x 3.94"W x 18.3"H / 380L x 100W x 465H mm			24"L x 19"W x 9"H / 600L x 480W x 230H mm	
Net Weight	5.8 lb / 2.6kg	7.3lb / 3.3kg		31lb / 14kg	
Shipping Weight	8.1lb / 3.7kg	9.5lb / 4.3kg		36lb / 16kg	
Other Features	Calibrate in kg or lb, calibration lock via internal switch				

*Calibration weights not included

Approvals

- **Electrical/Emissions:** Meets requirements of approval agencies: UL/CSA (adapter), FCC, CE Safety EN60950, EMC EN61326
- **Quality:** OHAUS quality management system registered to ISO 9001:2000

Outline Dimensional Drawings

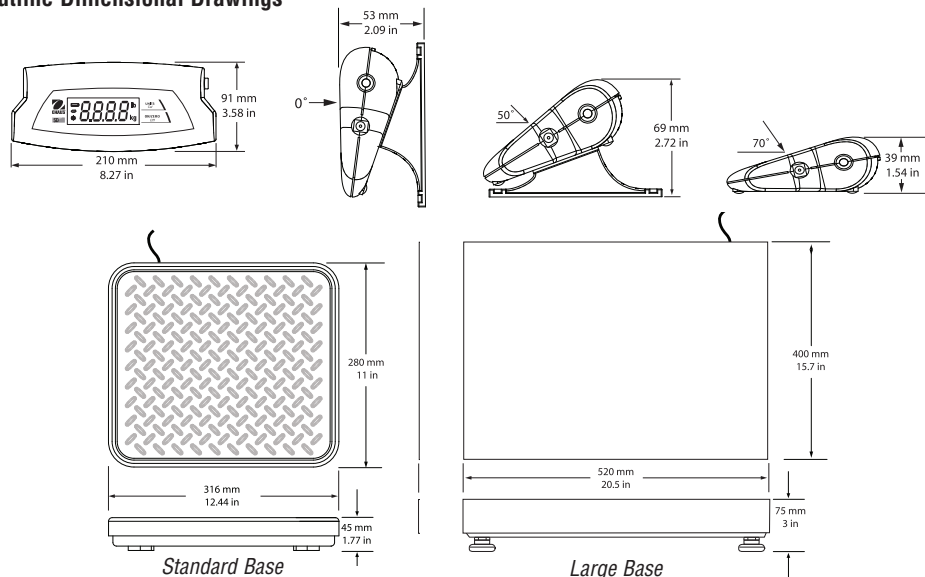

Hills Scales Pty Ltd
Tel.: (02)8850 4666
Web: www.hillscales.com.au
Email: sales@hillscales.com.au