

EC Series

Compact Bench Counting Scale



OHAUS EC Series Counting Scale – Speed, Accuracy, and Portability for Counting Operations

OHAUS EC Series Counting Scales are economical and designed for fast, accurate operation. Ideally suited for annual inventories, parts rooms, rentals and other counting applications, with an internal counting resolution of 1:600,000, OHAUS EC Counting Scales offer accuracy, durability and portability in one practical design.

Standard Features Include:

- Three-window, backlit LCD with fast display of weight, average piece weight and parts count
- Full counting keypad with numeric keys
- Pre-set Tare and dedicated TARE and SAMPLE keys for fast operation
- Pound or gram weighing units
- 10 Average Piece Weight memory locations for commonly-counted parts
- Accumulator function for weight and parts count
- Auto-optimization feature recalculates APW constantly for enhanced parts counting accuracy
- 80-hour Internal rechargeable battery with power-saving Auto-shut off feature
- Adjustable filtering level and Auto-Zero Tracking for weighing in industrial condition

EC Series Compact Bench Counting Scale

Flexible Operation for Counting Applications

The EC Counting Scale offers features for fast and accurate use:

- **Fast Sampling** – Enter the number of pieces in your sample, press the dedicated Sample key, and start counting.
- **Manual APW Entry** – For parts with an established Average Piece Weight, just input the APW value, press the dedicated APW key, and start counting.
- **Auto Optimization** – Start with a small sample size of 10, and then add random lots of pieces (below original sampling size) to increase your Average Piece Weight accuracy. The EC Counting Scale continues to recalculate the APW with each batch of parts you count.
- **Dedicated Keys** – The EC Counting Scale has dedicated keys for the most common counting operations – Sample, Tare, Zero, APW entry, and Pre-Set Tare entry.
- **Low Weight Alerts** – If the total weight or APW is too low, the EC Counting Scale will warn the user.
- **Flexible Taring** – Preset tare weights can be quickly entered via the keyboard, or use the Tare key.
- **Accumulation** – Use the dedicated memory key to accumulate weighments on the platform. The EC Counting Scale can display total weight accumulated, number of weighments, and a total parts count.
- **APW Memories** – 10 memory locations for storing commonly-used part weights, easily accessed using the numeric keypad.
- **Portability** – Designed for portable counting applications, the EC Counting Scale offers integrated carry handles and an internal rechargeable battery.

Outline Dimensional Drawings

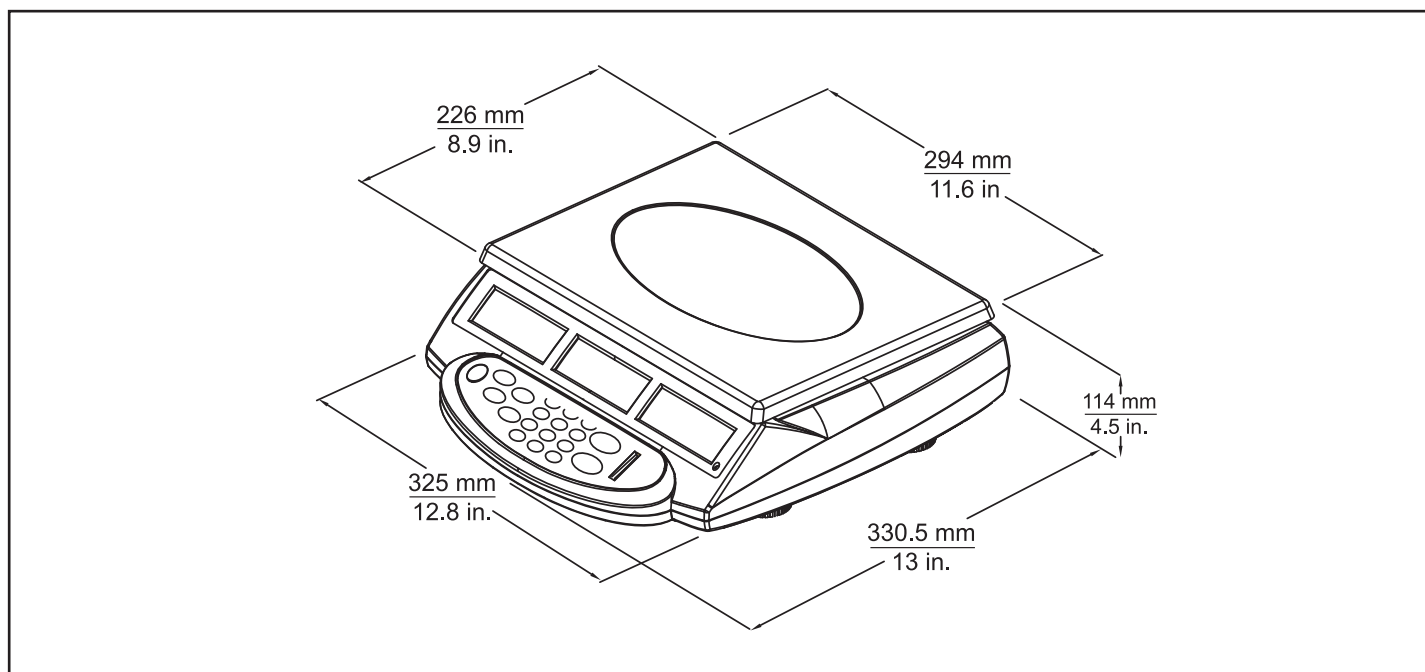

OHAUS EC Counting Scales: Features at a Glance

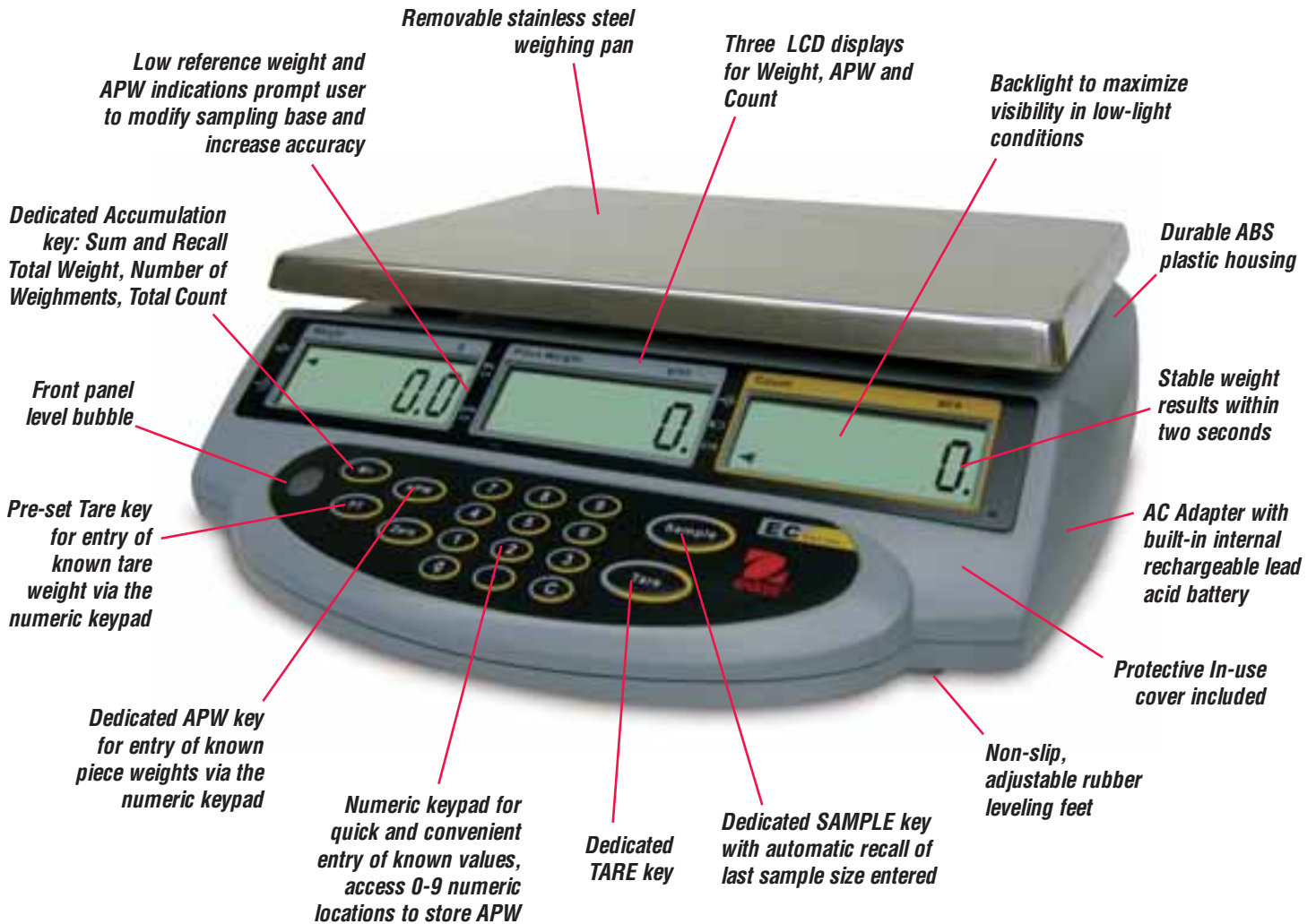

A Wide Range of Counting Applications and Industries:

- In-Process Parts Counting
- Receiving
- Shipping
- Warehousing
- Stock Rooms
- Rentals
- Inventory Control
- Kitting/Packaging
- Prepackaging
- Quality Control and Assurance
- Agriculture
- Automotive
- Electronics
- Printing
- Manufacturing
- Retail
- Ticket Counting
- Pull Tab Counting
- Catering
- Print Shops



Integrated handles in the housing allow easy transport of the EC Scale

EC Series Compact Bench Counting Scale

Specifications

Capacity x Readability	3000 g x 0.1 g 6 lb x 0.0002 lb	6000 g x 0.2 g 15 lb x 0.0005 lb	15000 g x 0.5 g 30 lb x 0.001 lb	30000 g x 1 g 60 lb x 0.002 lb
Minimum Recommended Sample Weight	1 g / 0.002 lb	2 g / 0.005 lb	5 g / 0.01 lb	10g / 0.02 lb
Minimum Recommended APW	0.01 g / 0.00002 lb	0.02 g / 0.00005 lb	0.05 g / 0.0001 lb	0.1 g / 0.0002 lb
Maximum Internal Counting Resolution	1:600,000			
Maximum Displayed Resolution	1:30,000			
Weighing Units	lb or g (menu selected)			
Application Modes	Weighing, Counting, Accumulation			
Display	3-Window, backlit LCD 0.75in / 19mm High, 6-digit, 7-segment			
Display Indicators	Stability, Center of Zero, Tare, Low Sample Weight, Low APW, Accumulation, Battery Status, Weighing Unit			
Memories	10 locations for APW			
Keyboard	7 function (Tare, Sample, APW, Zero, Pre-set Tare, M+, Cancel), 11 numeric membrane keys			
Tare Range	To Full Capacity by Subtraction (except EC15, up to 20 lbs/10kg only)			
Stabilization Time	≤ 2 seconds			
Auto-Zero Tracking	0 (off), 0.5, 1, 2, 3d			
Safe Overload Capacity	120% of capacity			
Power	AC Adapter (included) / Internal rechargeable lead acid battery (included)			
Battery Life	80 hours continuous use with 12 hour recharge time			
Calibration	External, with user-selectable calibration weight			
Operating Temperature	32° to 104° F / 0° to 40° C			
Pan Size (in / mm)	11.6 x 8.9 / 294 x 226			
Scale Dimensions (in / mm)	12.8 W x 13 D x 4.5 min H / 325 W x 330.5 D x 114 min H			
Shipping Dimensions (in / mm)	17.3 W x 14.2 D x 6.3 H / 440 W x 360 D x 160 H			
Net Weight (lb / kg)	9.2 / 4.2			
Shipping Weight (lb / kg)	11.7 / 5.3			
Item Number	EC3	EC6	EC15	EC30

Physical and Operational Features:

Removable stainless steel weighing pan, clear plastic in-use protective cover, durable ABS plastic housing, shipping screw to avoid damage to sensitive components, backlit LCD displays, rubber user-adjustable leveling feet, front panel leveling bubble, internal rechargeable lead acid battery, external AC wall adapter, large dedicated Tare and Sample keys, dedicated memory, pre-set Tare, APW and Zero keys, numeric keypad, user-selectable Auto-Off, Pre-set Tare, Auto-optimization of APW, low APW alert, user-selectable environmental filtering, Auto-Zero Tracking, 10 APW memory locations, Accumulation function with recall of total weight, number of weighments and total parts count.

Industry Leading Quality and Support

Our rugged construction and stringent quality control have been hallmarks of all OHAUS products for over a century.



Hills Scales Pty Ltd
Tel.: (02)8850 4666

Web: www.hillscales.com.au
Email : sales@hillscales.com.au