

# EHB SERIES PRECISION WEIGHING SCALE

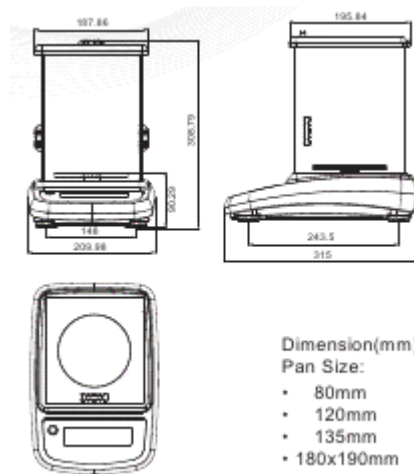

- **Trade Approved NMI 6/4C/271**
- Capacities from 150g to 6000g
- External resolution up to 300,000 (none approved model) or 60,000d (approved model)
- Responds quickly with accurate weights
- 7 embossed membrane keys
- Application include: piece counting, percentage weighing, accumulation, unit conversion.
- Battery provide up to 40 hours of continuous use
- Wind shield is standard for models that capacity less than 1kg
- Standard stainless steel pan
- Bar graphic capacity indicator
- Standard RS-232 can connect to a printer or computer
- Optional USB interface, blue tooth and below weighing
- Optional internal calibration weight



## Specifications:

Model	EHB-M					EHB+		EHB++		
Display	16.5mm digits high LCD display									
Capacity	150g	300g	600g	1500g	3000g	6000g	200g	2000g	300g	3000g
Readability	0.002g	0.005g	0.01g	0.02g	0.05g	0.1g	0.001g	0.01g	0.001g	0.01g
Pan size	Φ80mm	Φ120mm	Φ135mm	Φ180mm	190mm	190mm	Φ80mm	Φ120mm	Φ80mm	Φ120mm
Max. Divisions	60,000d/6000e					200,000d	300,000d			
Keyboard	7 membrane keys									
Housing	ABS plastic									
Attachment	Wind shield			None			Wind shield			
ADC	Sigma delta									
ADC update	≤1/10 second									
Operate Temp	5°C~+40°C									
Power	AC adapter(12V/500mA), Rechargeable battery(6V/1.2A)									
Gross weight	3.5kg			2kg			3.5kg			

