



OHAUS Aviator™ 7000

Advanced Price Computing Retail Scale



Ethernet Connection

The Aviator 7000 can be connected to an external Point of Sale (POS) device or an electronic cash register via RS232 or USB for easy integration into existing systems.



Two Model Options

The Aviator 7000 is available in a compact or tower model. The compact model is suitable for high bench tops and big boxed items, while the tower model is perfect for lower bench tops and general weighing items.



Multiple Weighing Ranges

The compact model covers weighing range: 3kg/1g, 15kg/5g and 30kg/10g making it suitable for various weighing requirements.



Separate Tare Line

Both the compact and tower models contain a large four line LCD display including a separate tare line which highlights the preset tare weight, making daily tasks more simple.



The Aviator 7000 guarantees robustness, operating speed and accuracy whatever the retail environment.

Additional features include:

Multiple Operation Functionalities - the 100 price look up (PLU) memory and 32 preset keys enable users to set tares and perform zeroing.

Practical Design Features - ergonomic grips, integrated cable storage, and POS protocol support each provide secure and easy transportation.

Trade Approval - approved and certified by National Measurement Institute (NMI) means the Aviator 7000 maintains the highest accuracy and allows quick data signal processing.

Stainless Steel Construction - large, robust and water resistant stainless steel weighing plate for hygienic weighing of any product.

Aviator™ 7000 *Advanced Price Computing Retail Scale*

General Specifications

Application Modes	Weighing and price computing, POS protocol support
Features	Choice of battery NiMH or standard D size, large backlight LCD display, adaptor and cable case storage, ergonomic grips, easy adjustable feet, sleep Mode and communications port

Specifications

Model	A71P3N	A71P15TN	A71P30N
Capacity	3kg/1g	15kg/5g	30kg/10g
Construction	Removable stainless steel pan, high grade polymer housing		
Display	LCD with backlight; Weight Display: 6 digits Tare display: 4 digit Price per kg: 6 digits Price to pay display: 7 digits		
Display Indicators	Zero, Tare, 100g, Change, Hold		
Keyboard	32 light touch keys, 16 preset keys		
Net Weight	Tower: 3.73kg Compact: 3.42kg		
Operating Temperature	-10°C ~ +40°C		
Pan Size	240 x 337mm		
PLU Quantity	100		
Power	Power adapter: 100~240VAC, 50/60Hz Battery: 6 NiMH or D-Cell batteries		
Scale Dimensions	350mm x 369.5mm x 147mm without tower 350mm x 369.5mm x 438mm with adaptable tower		
Communication	RS232/USB		

Outline Dimensions

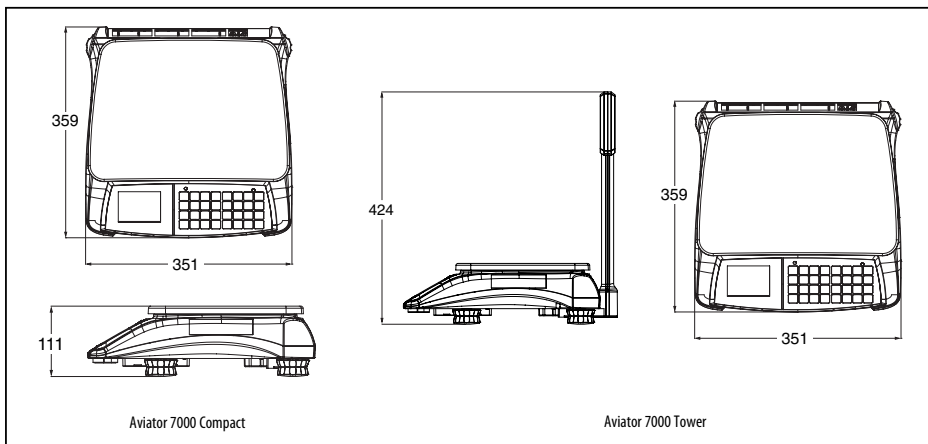

Accessories

- RS232 POS connector
- USB POS connector

Document is subject to technical changes

www.ohaus.com

ISO 9001:2008
Registered Quality Management System

© Copyright Ohaus Corporation

